

1200 MIXER

The Plaster/Mortar mixer
designed exclusively
for the professional

WESTERN
MANUFACTURING, INC.



Totally enclosed transmission & clutch are immersed in oil for a long, trouble free life.

Largest power source selection.

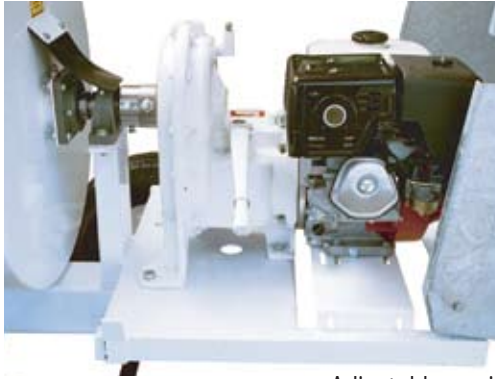

Solid base-mount transmission.

Adjustable engine mount for a perfect engine alignment.

Longest Lasting Paddle Shaft Seals

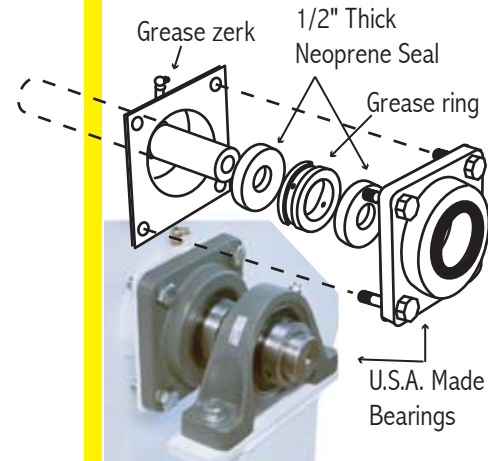

Powder coated mixer with galvanized engine cover for extreme corrosion resistance.

Heavy duty safety grate with built-in bag cutter.

Thicker round tubing dump handle for a better grip.

Tough 12-gauge swing away engine cover makes it the longest lasting.

Drum and spout designed for a perfect wheelbarrow dumping function.

Open back for maximum ventilation

FAST-MIX 6 paddle design.
Standard paddles - Fabricated steel.
Optional paddles - Weldable grade cast iron.
Steel or Rubber blades.

7-stack Leaf spring suspension for a smooth ride.

Double bearing pivot point provides an easy and smooth dumping action.



Structural tubing forms the strongest frame available.

Durable 3/16" thick steel drum.

Heavy duty schedule 80 removable tow bar Available with pin type, 2" ball or loop coupler.

SPECIFICATIONS

Power Source..... Honda GX390 13HP (Gas)
Robin 11.5HP (Gas)
Kohler 15HP (Gas)
Hatz 1D41 7.6HP (Diesel)
Lombardini 10HP (Diesel)
5HP 1Ø 208/230V Electric
5HP 3Ø 230/460V Electric

Drive..... Oil Bath Enclosed Transmission
Tires..... B78x13
Suspension..... 7-stack Leaf Spring

Capacity - cu.ft..... 12 cu.ft.
Capacity - bags..... 4
Average Weight* 1220 lbs. (549 kg)
Length w/tongue..... 108 inches (275 cm)
Length without tongue..... 78 inches (199 cm)
Width..... 57 inches (145 cm)
Height w/handle..... 77 inches (196 cm)
Height without handle..... 60 inches (153 cm)

* Varies depending on options selected.
All specifications and features are subject to change without notice.